



TECHNISCHE
UNIVERSITÄT
WIEN

Vienna University of Technology

Overview of full-scale gasification processes

IEA Bioenergy ExCo Meeting
York, October 2010

Dr. Reinhard Rauch

Vienna, University of Technology
Institute of Chemical Engineering

Participation in IEA Bioenergy is financed by



Content

- Synthesis gas
- Technology
- Examples

Why Gasification

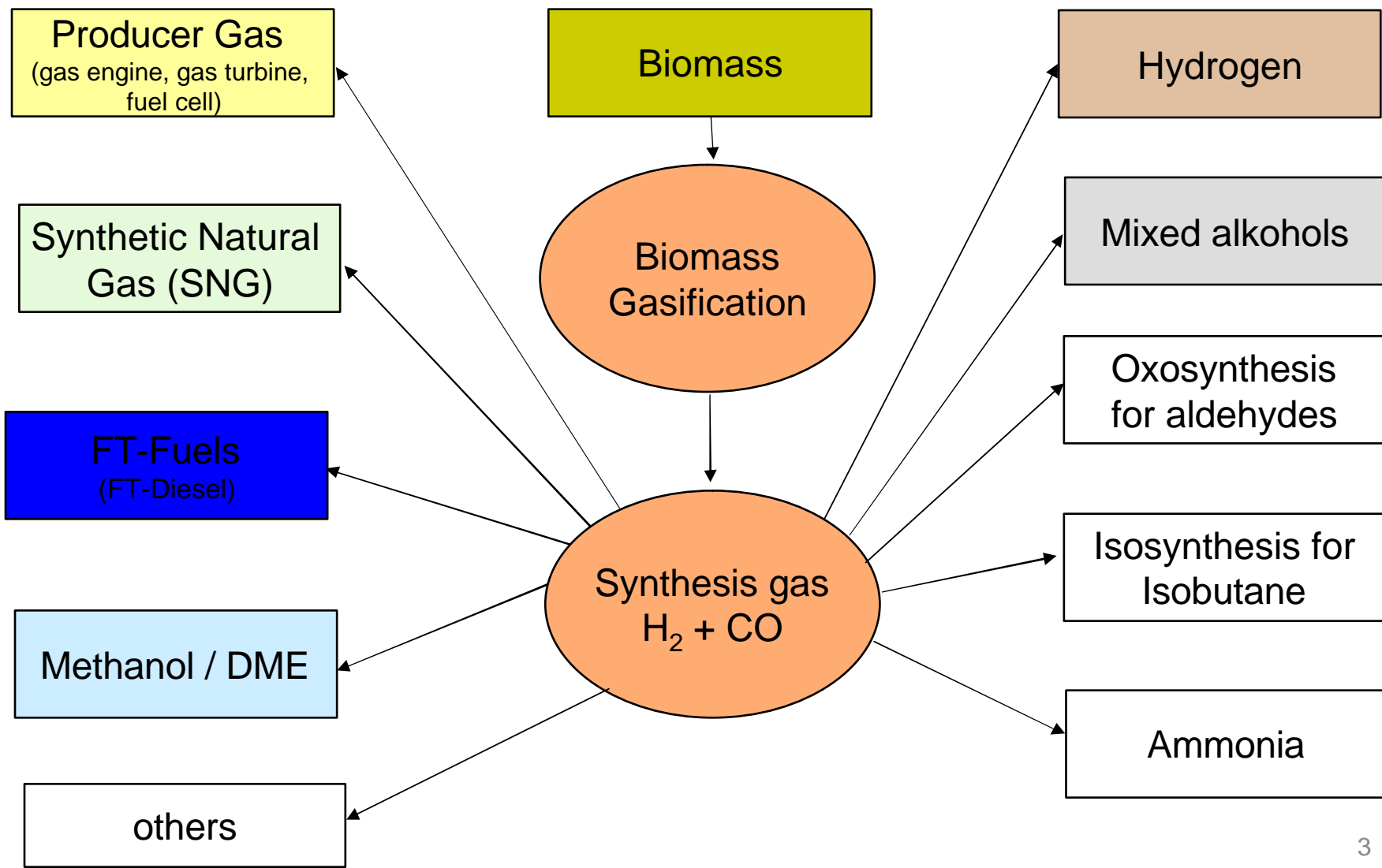

Actual Usage of Synthesis Gas

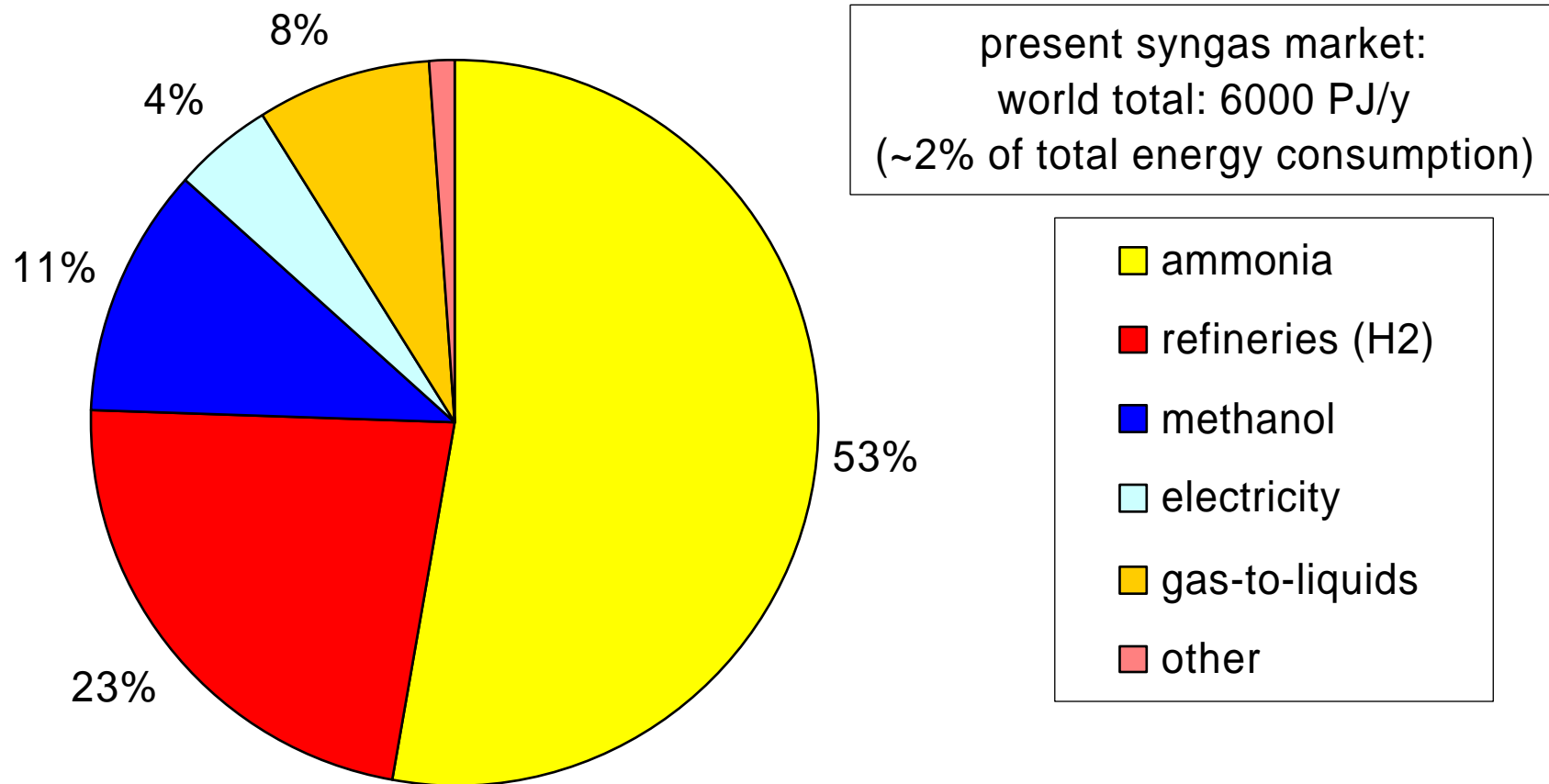

Predicted world syngas market in 2040

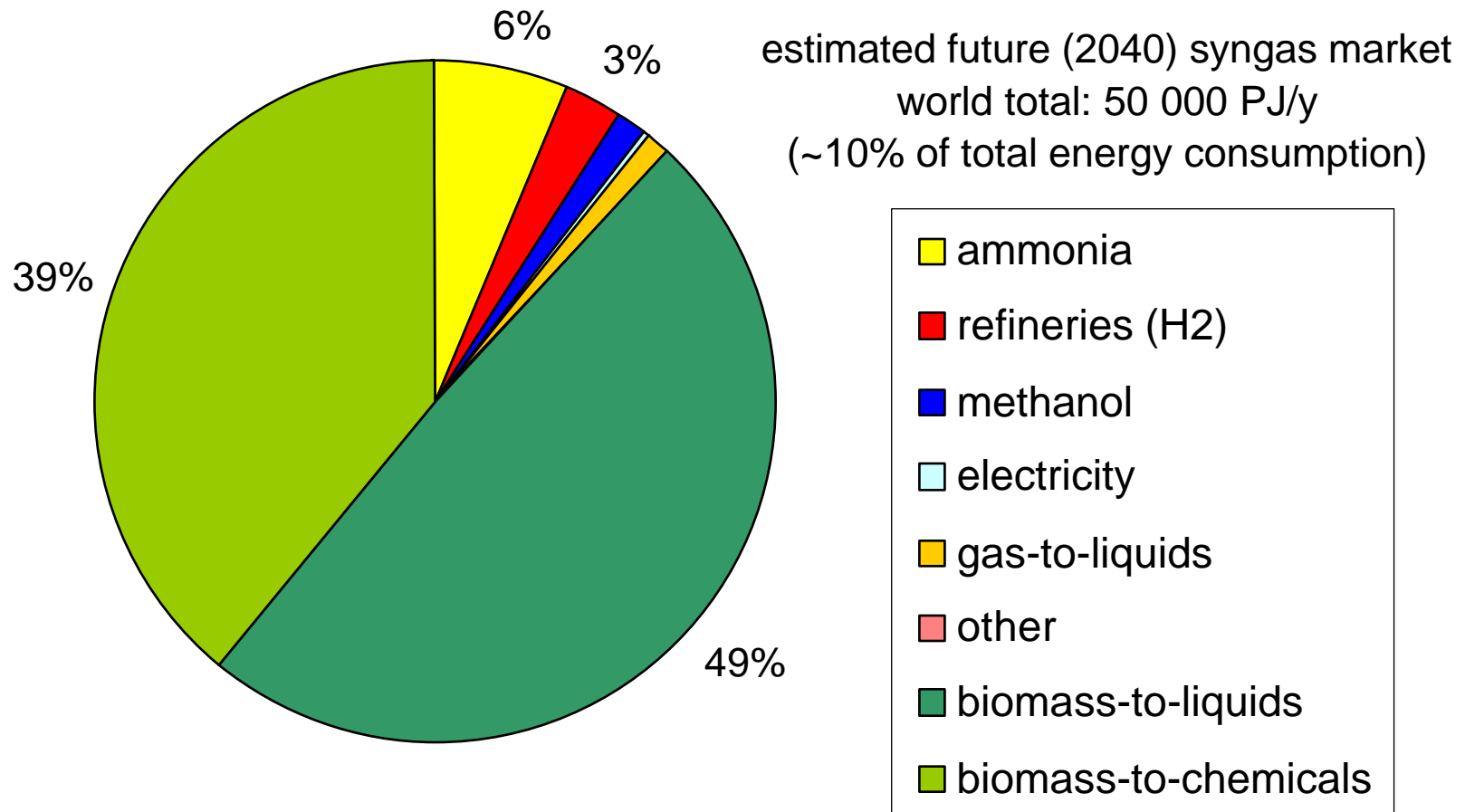

Gasifiers, based on gasification media

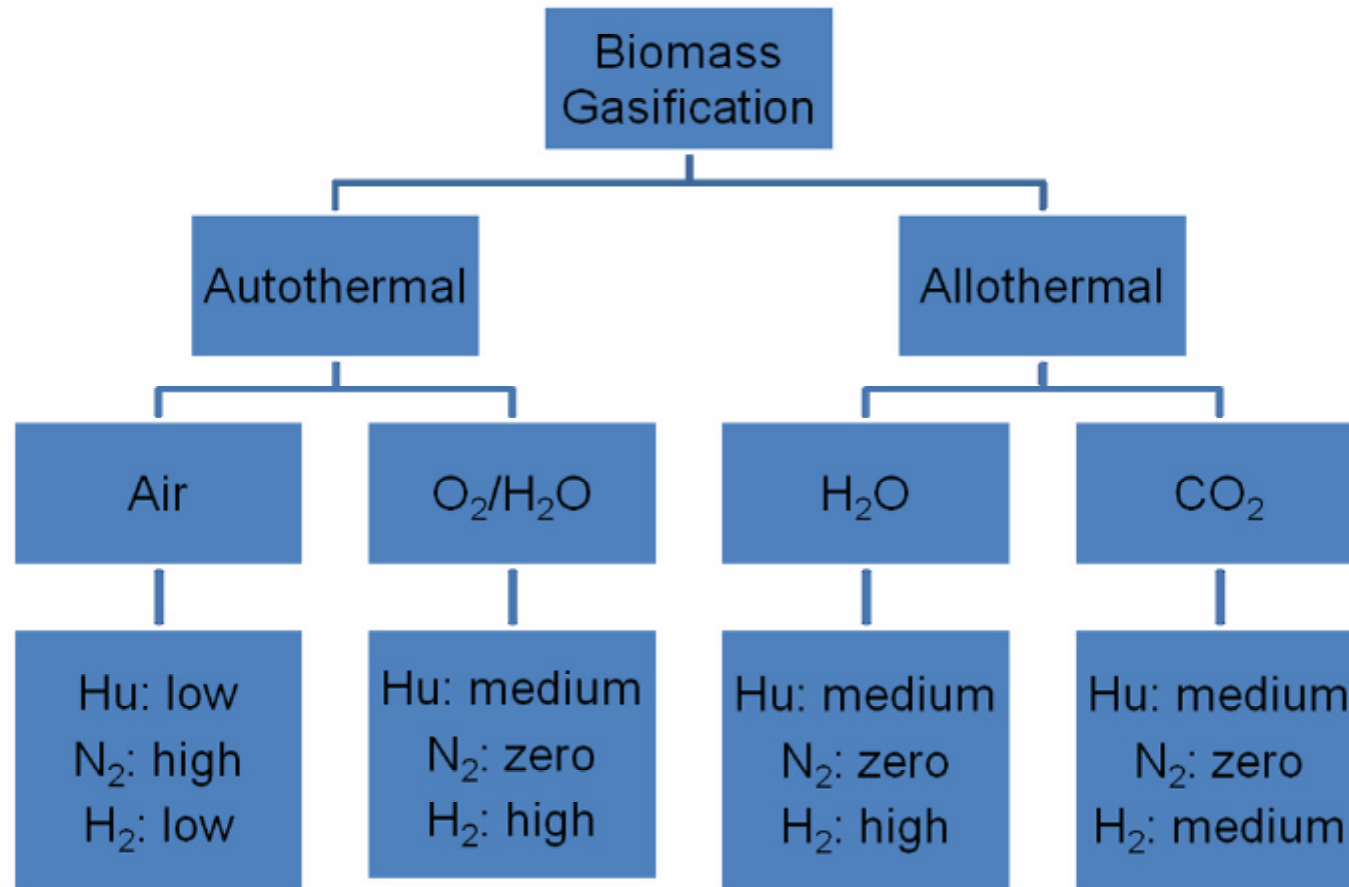

Reactors for Gasification

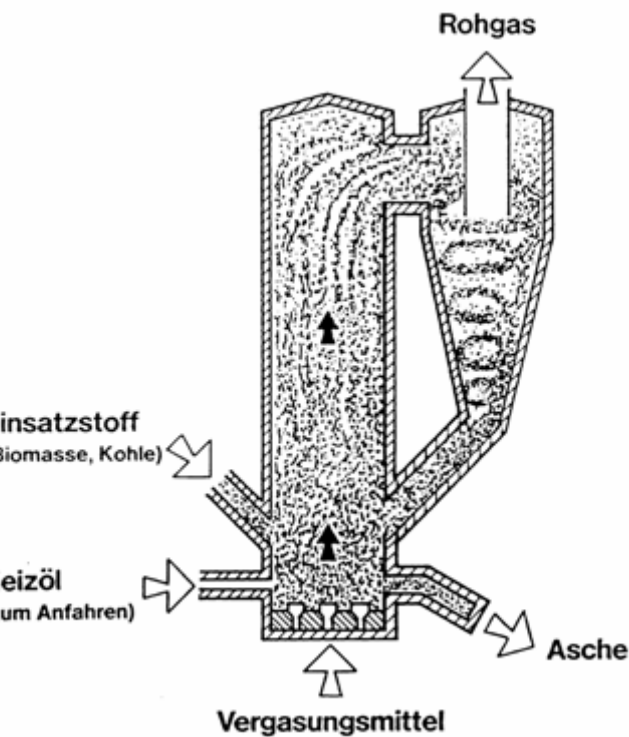

Fluidised Bed (Steam/O₂)

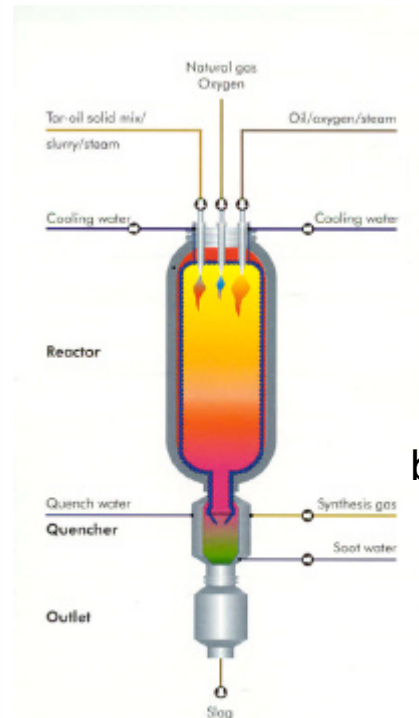

Entrained Flow (O₂)

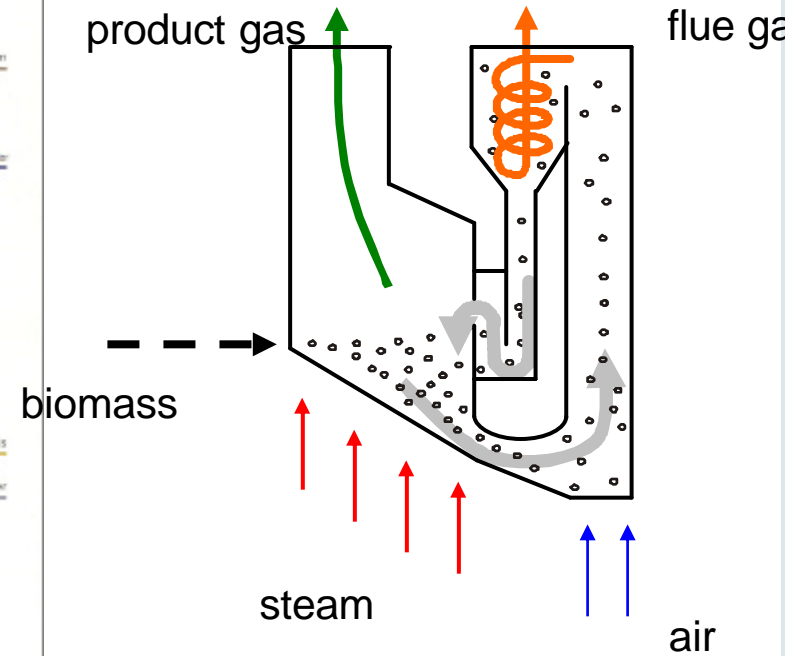

Dual Fluidised Bed (Steam)

Technology	Gasification agent	Type of reactor	Location	Status
MAER	steam	dual fluidised bed	Geislingen (GER)	Planning of Demoplant
Partfuel	oxygen/ steam	CFB	Clausthal (GER)	Pilot plant in operation
Bioliq	oxygen	staged gasification (decentral + central)	Karlsruhe (GER)	Commissioning of Demoplant
BioMCN	oxygen	entrained flow	The Netherlands	Planning of Demoplant
Carbo V	oxygen	staged gasification	Freiberg (GER)	Commissioning of Demoplant
Chemrec	oxygen	entrained flow	Sweden	Pilot plant in operation
Chrisgas	oxygen/ steam	CFB	Värnamo, Sweden	Commissioning of Demoplant
Inerkem	oxygen/ steam	BFB	Canada	Construction of Demoplant
ICFB / Repotec	steam	dual fluidised bed	Güssing (AT)	In operation
ICFB / Ortner	steam	dual fluidised bed	Oberwart (AT)	In operation
GoBiGas	steam	dual fluidised bed	Göteborg, Sweden	Planning of Demoplant
Heat Pipe Reformer	steam	indirekt fluidised bed	Pfaffenhofen (GER)	Commissioning of Demoplant
MILENA	steam	dual fluidised bed	ECN, (The Netherlands)	Comissioning of pilot plant
Range Fuels		staged gasification	US	Construction of commercial plant
Ultra Clean Gas	oxygen/ steam	CFB	Finland	Commissioning of

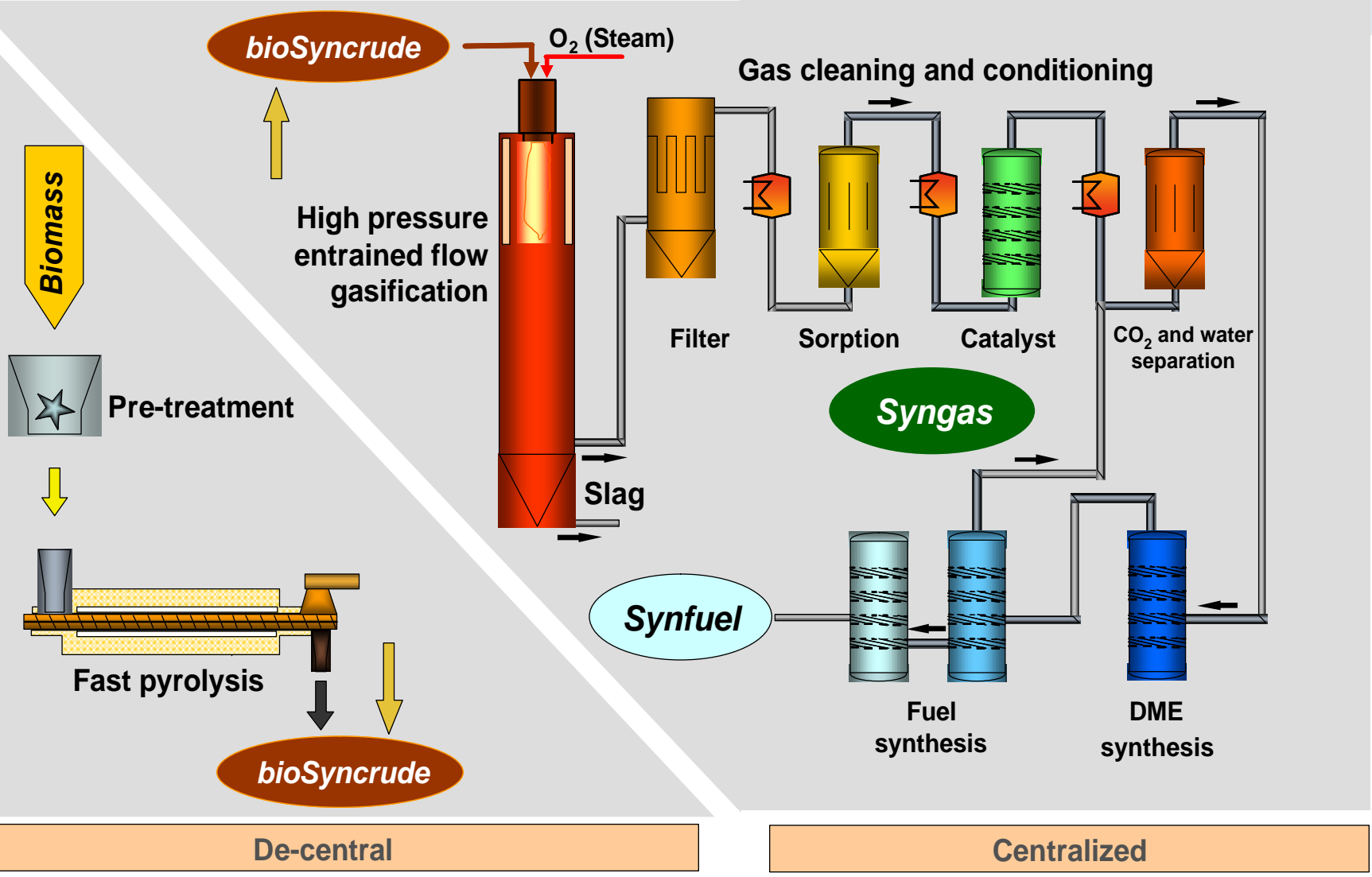

BioMCN

Methanol Chemistry Netherlands

- raw glycerin upgrading
- 30-40% glycerin in Natural Gas reformer, ~150 kton/y bio-methanol (~150 MW_{bio-methanol})
- Looking for options to go to 100% bio-methanol: gasification



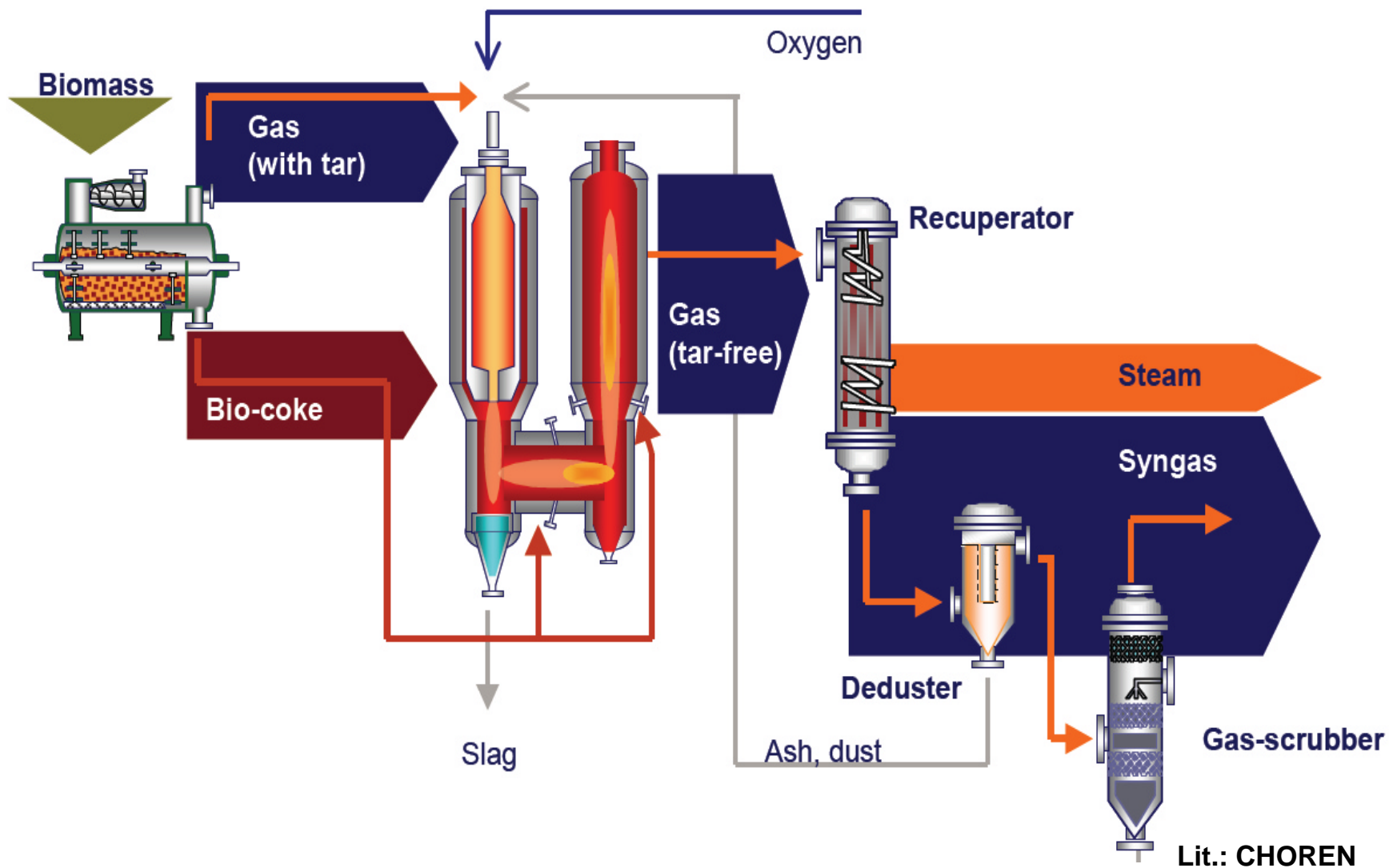

DP1 integration with DME pilot

New process units downstream the DP-1 plant in Piteå

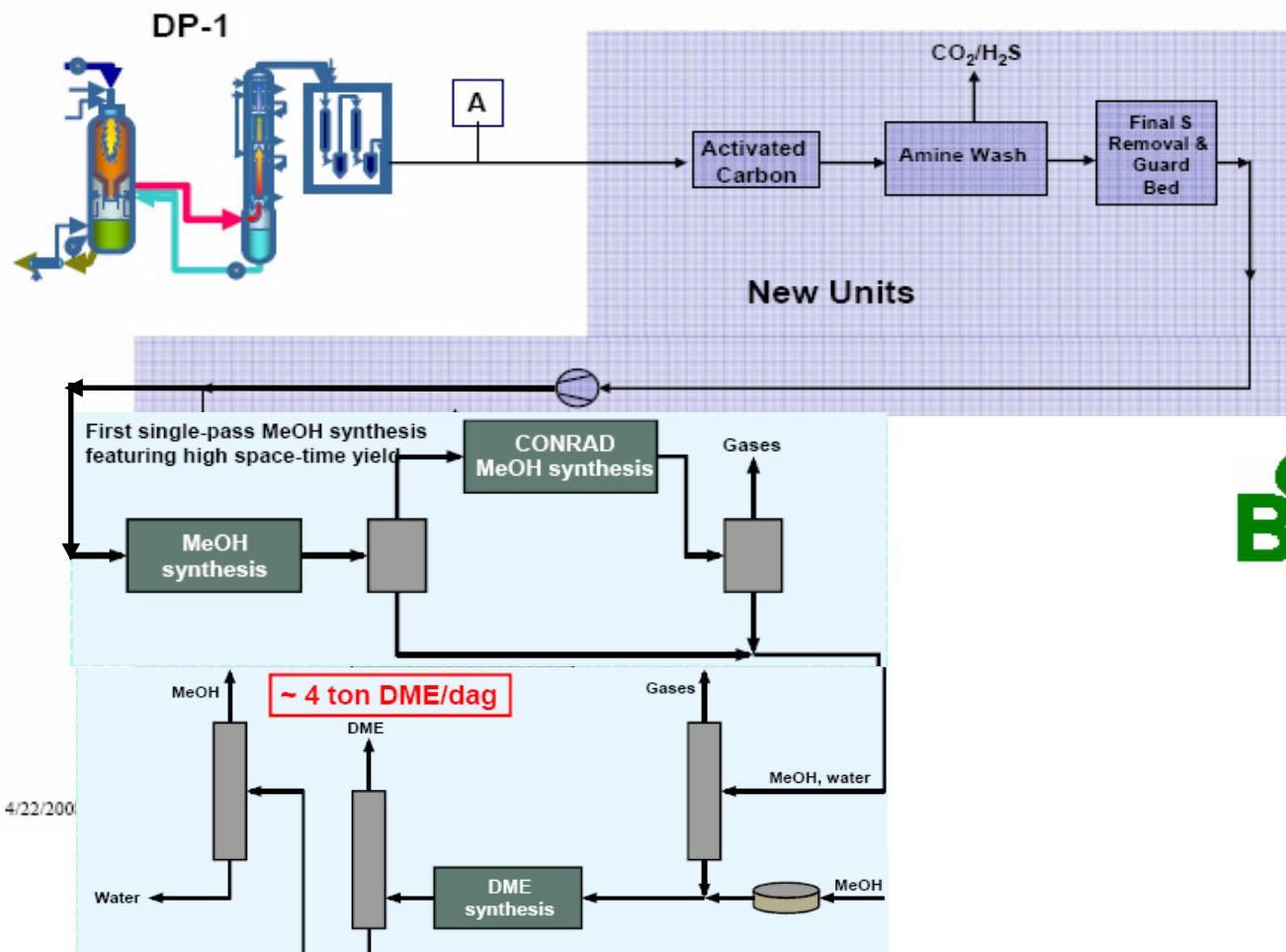

VVBGC Project

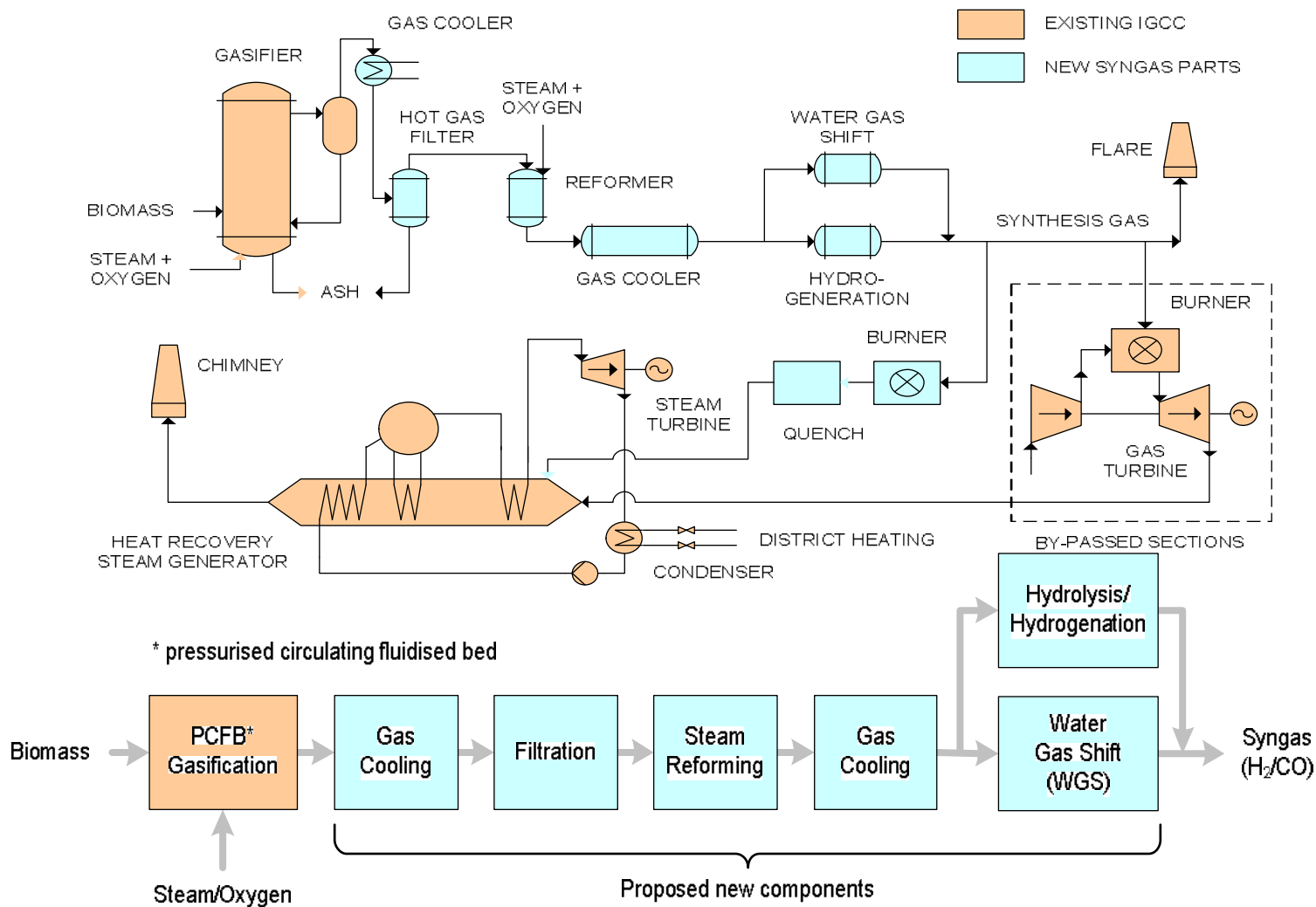

Biomass CHP Güssing



Gasifier

BioSNG Demo

Technikum

BioSNG Fuelling
Station

Experience: 10.000 hours of operation



FICFB Ulm, Germany



Biomass to SNG: GOBIGAS

GoBiGas – phase 1

Production:		Consumption:	
Bio-SNG	20 MW	Fuel (pellets)	32 MW
District heating	4 MW	Electricity	2,5 MW
Heat to heat pumps	8 MW	RME (bio-oil)	0,5 MW

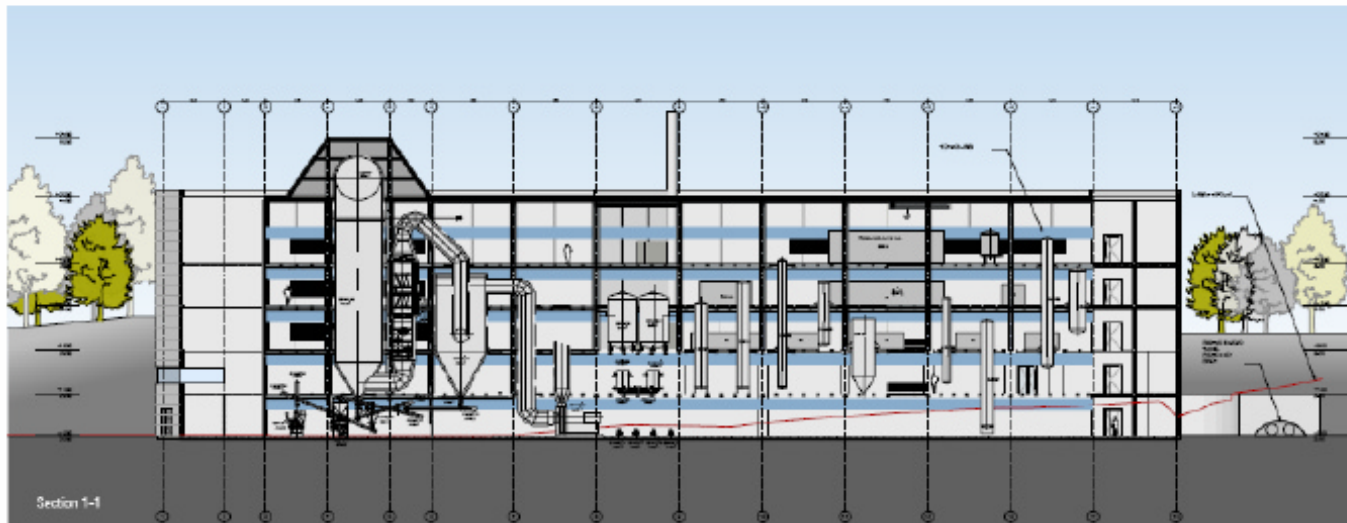

Stora Enso / Neste Oil Joint Venture for FT BTL Diesel Fuel

50/50 Joint Venture “NSE Biofuels Oy” to first develop technology and later produce next generation renewable diesel crude from wood / forest residues

Currently building a 12MW demonstration plant in Stora Enso’s Varkaus mill, to be in use spring 2009

Investment decision for a commercial scale plant when the parties have enough experience from the demonstration plant

Strong development consortium

- Joint Venture partners:
- Testing & research partner:
- Gasification supplier:

STORAENSO |
NESTE OIL

VTT

FOSTER WHEELER



Outlook: usage as synthesis gas



Summary

- Work on gasification of biomass is going on
- Political frame conditions are good, but there is the trend to electric cars
- Several Demoplants are on the way!