

Future challenges for AD to deliver economically and environmentally sustainable fuel and bioenergy

Charles Banks

UNIVERSITY OF
Southampton

Contribution of biogas technology



- Renewable energy
- Greenhouse gas emissions
- Waste management
- Environmental

Renewable energy

Grid injection – more than 150 schemes currently operational across EU



CHP- Germany >7000 plants producing 2.7MW of power supplying 4.5M homes

Vehicle fuel – can be coupled to CNG vehicle growth, about 25% worldwide



Heating and cooling – local application or for DCH or community projects

GHG - Savings in tonnes CO₂ per tonne ww processed)

- **cattle slurry:**

0.24 t fossil fuel displacement by using biogas as fuel

0.024 t prevention of fugitive emissions from tank storage

- **Food waste:**

0.74t CO₂eq assuming half of the methane potential from landfill is prevented

0.17t from electricity generated (at 35% efficiency)

0.057 t from savings over fertiliser produced using fossil fuels

- **Energy crops**

0.2t from electricity generated



Waste management

- Landfill Directive

- Municipal solid waste

- generation $400 \text{ kg person}^{-1} \text{ y}^{-1}$

- 60% organic

- Reduce biodegradable waste going to landfill to 35% of 1995 levels by 2014

- Many of these wastes have a high moisture content, making anaerobic digestion a good choice for energy recovery (e.g. UK $50 \text{ kg person}^{-1} \text{ y}^{-1}$ food waste)



Environmental contribution

- Recycling of nutrients
- Returns organic matter to land
- Helps in resource recovery
- Improves biosecurity

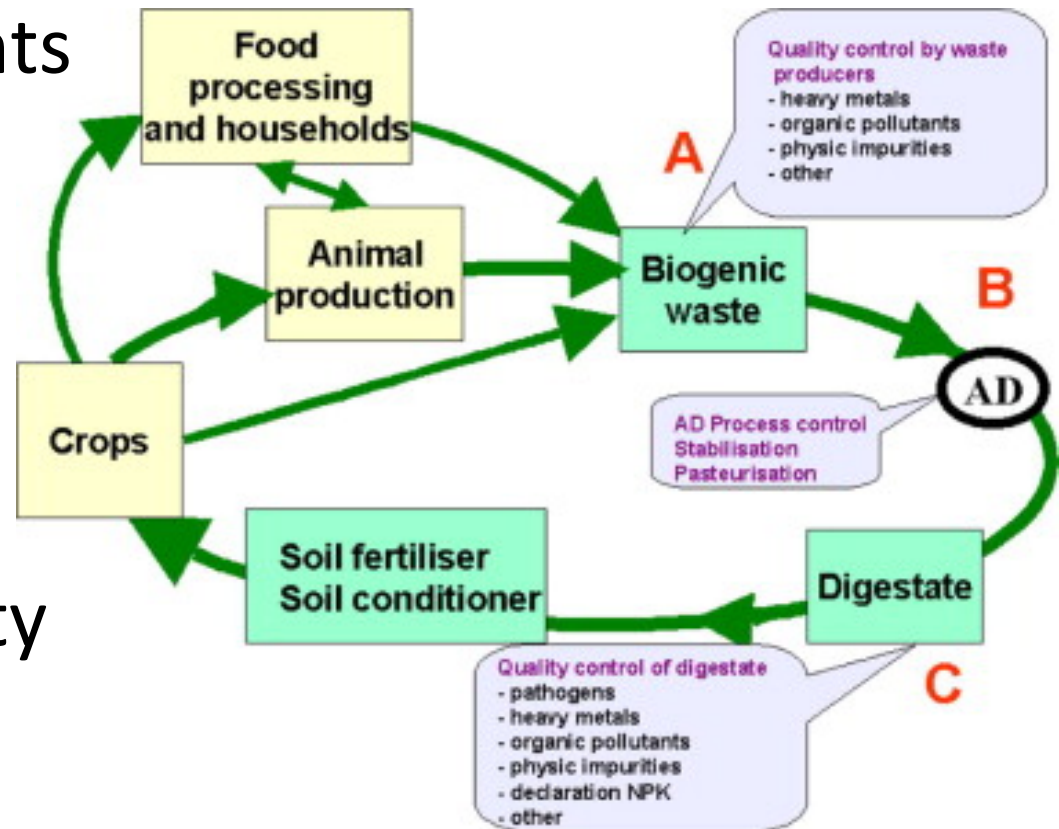

J.B. Holm-Nielsen et al (2009) Bioresource Technology , 100, 5478–5484

Drivers

- Biogas can deliver many benefits, but not necessarily all of them simultaneously!
- Direction and future development will depend on the drivers in place and include:
 - Subsidies
 - Penalties
 - Regulations
- These drivers are not uniform across different countries, and biogas will develop in different ways



Research needs

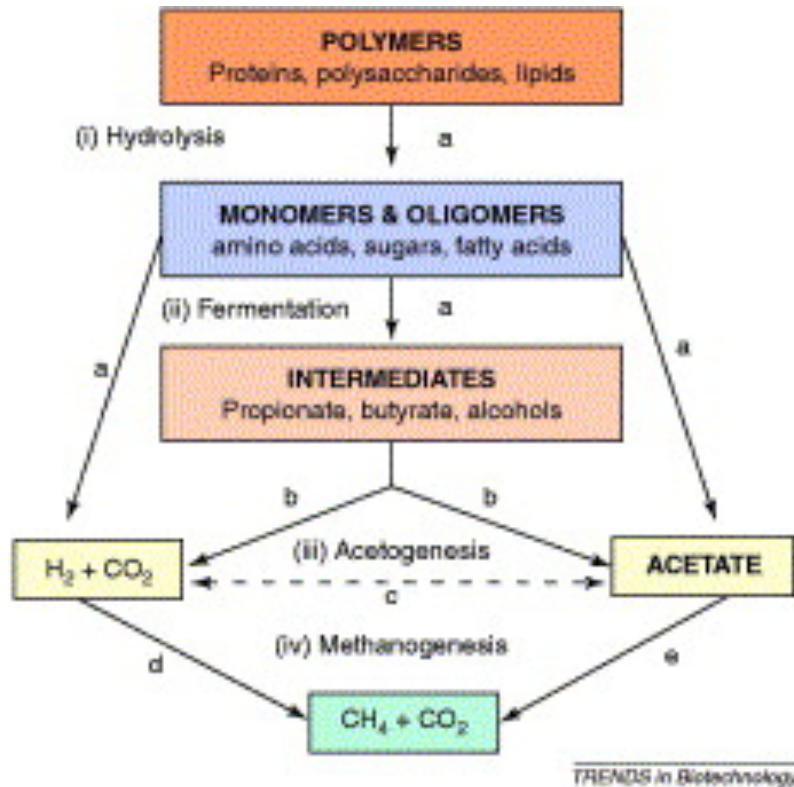

- Capturing more feedstock
- Ensuring sustainability and minimising environmental impact
- Improving biodegradability
- Optimising conversion
- Engineering design and process integration

Capturing more feedstock

- Exploiting the potential of manures and slurry through co-digestion
- Source segregation and improvement in biowaste quality
- Full integration of AD into biorefineries
- New substrates – micro and macro algae (freshwater and marine)

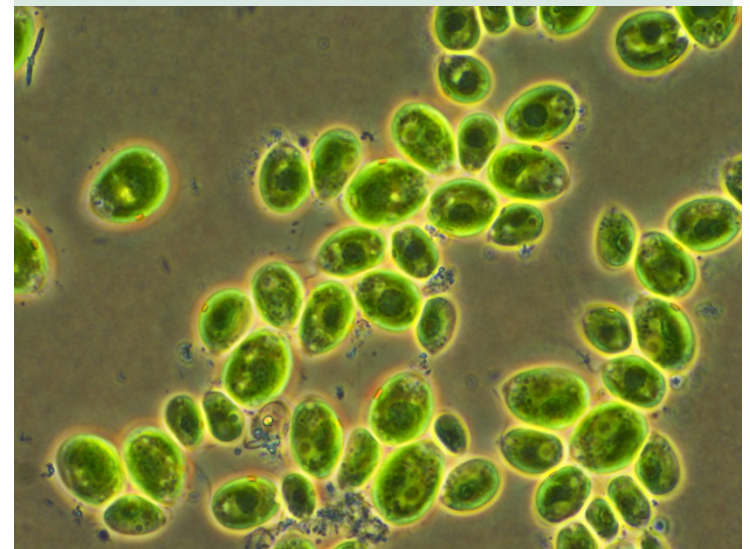
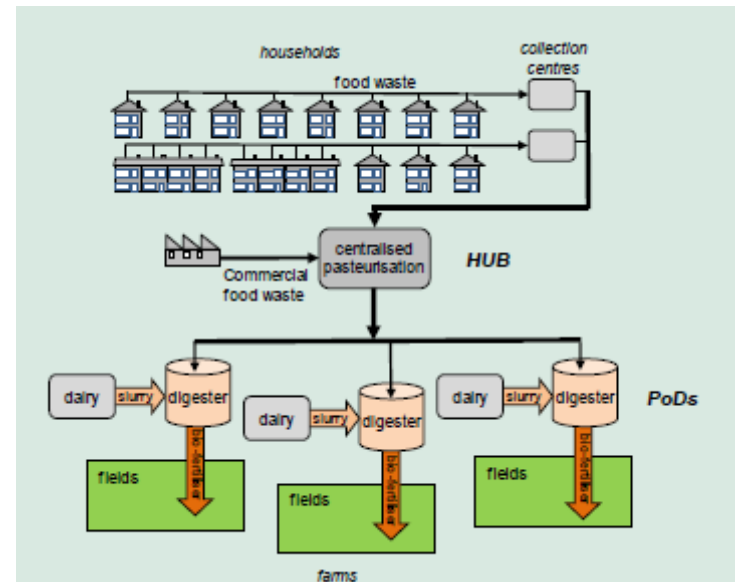

Ensuring sustainability and minimising environmental impact

- Sustainable management of energy crops
 - Crop rotations, catch crops, site adapted crops, EIA and biodiversity, life cycle assessment
- Ensuring the input quality of wastes so we do not compromise digestate use
 - Impact of digestate use on land, health risks to human and animal health and plants
 - Impacts or benefits in terms of GHG

Improving biodegradability

- How this can be achieved without cutting too deeply into the positive energy balance
- More research on methods to process difficult-to-degrade feedstocks
 - Heat treatments
 - Cavitation
 - Chemical treatments
- Development of new techniques
 - Enzymes?
 - Superbugs?

Optimising conversion

- Example.....
- Overcoming ammonia toxicity in food waste digestion in the UK
- Understanding the process, its biochemistry and requirements



VFA profiles

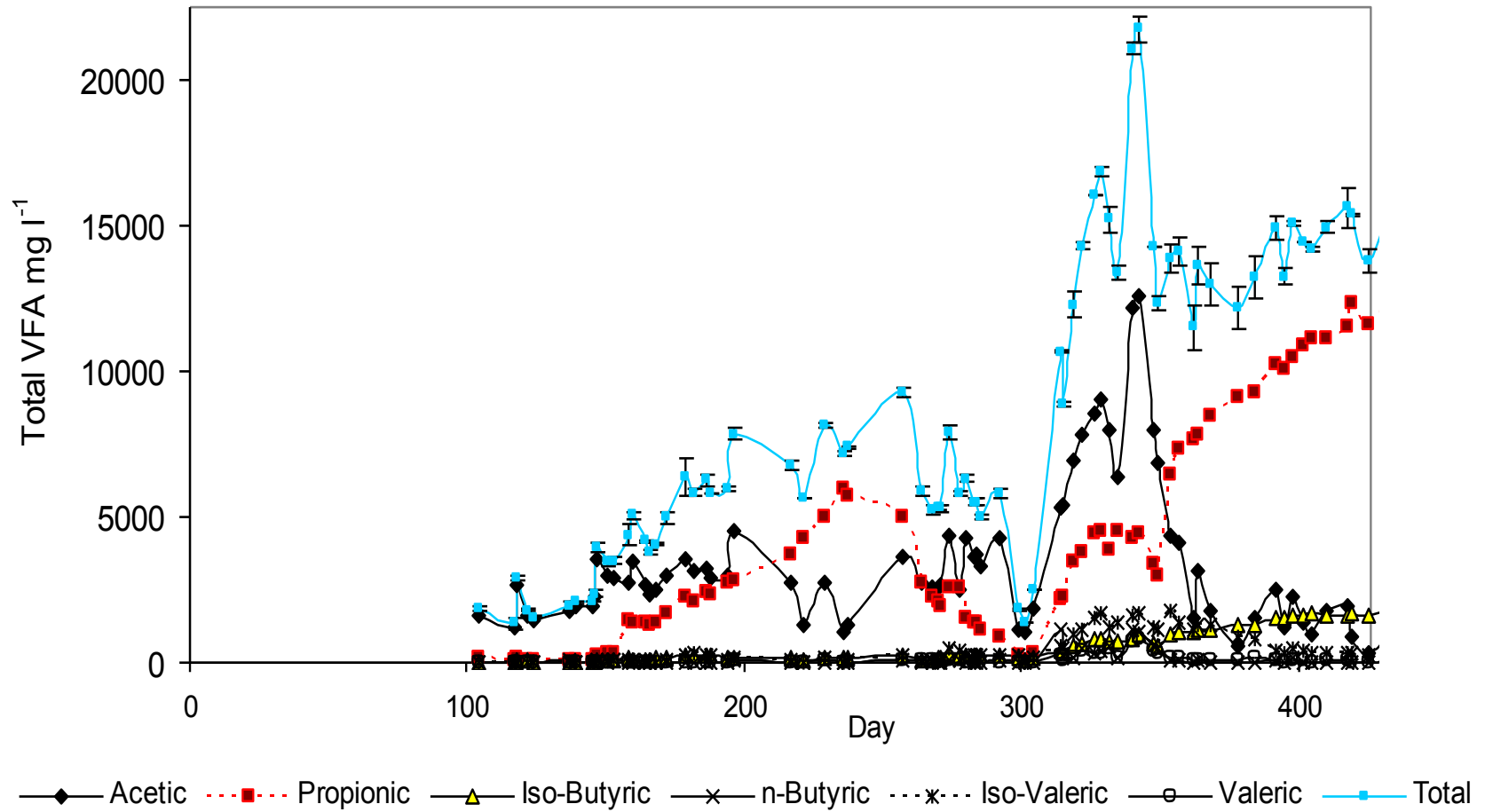

Theory proposed

- Propionic acid accumulation is due to insufficient capacity of hydrogenotrophic methanogens to synthesis formate dehydrogenase enzyme
- Requirement for Se as part of this enzyme complex
- Ammonia toxic to acetoclastic methanogens less toxic to hydrogenotrophic methanogens

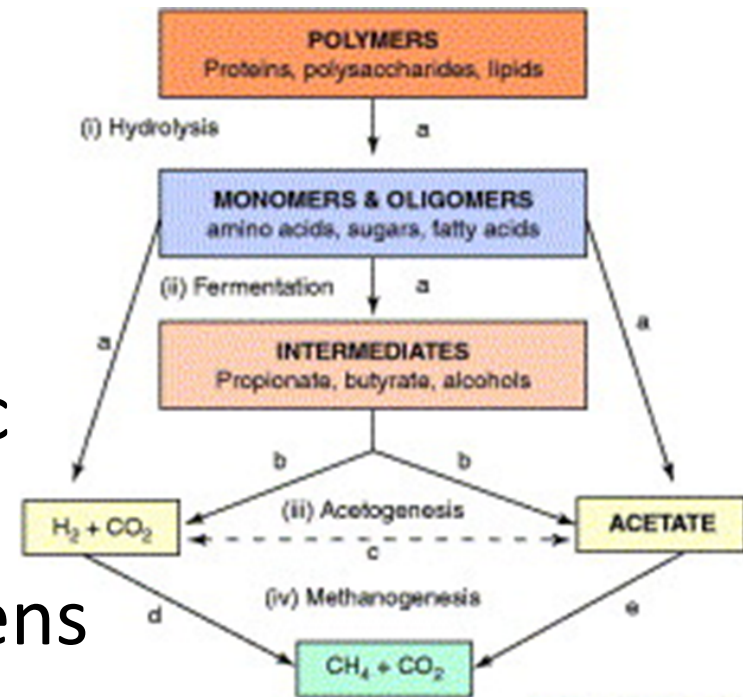

Laboratory studies

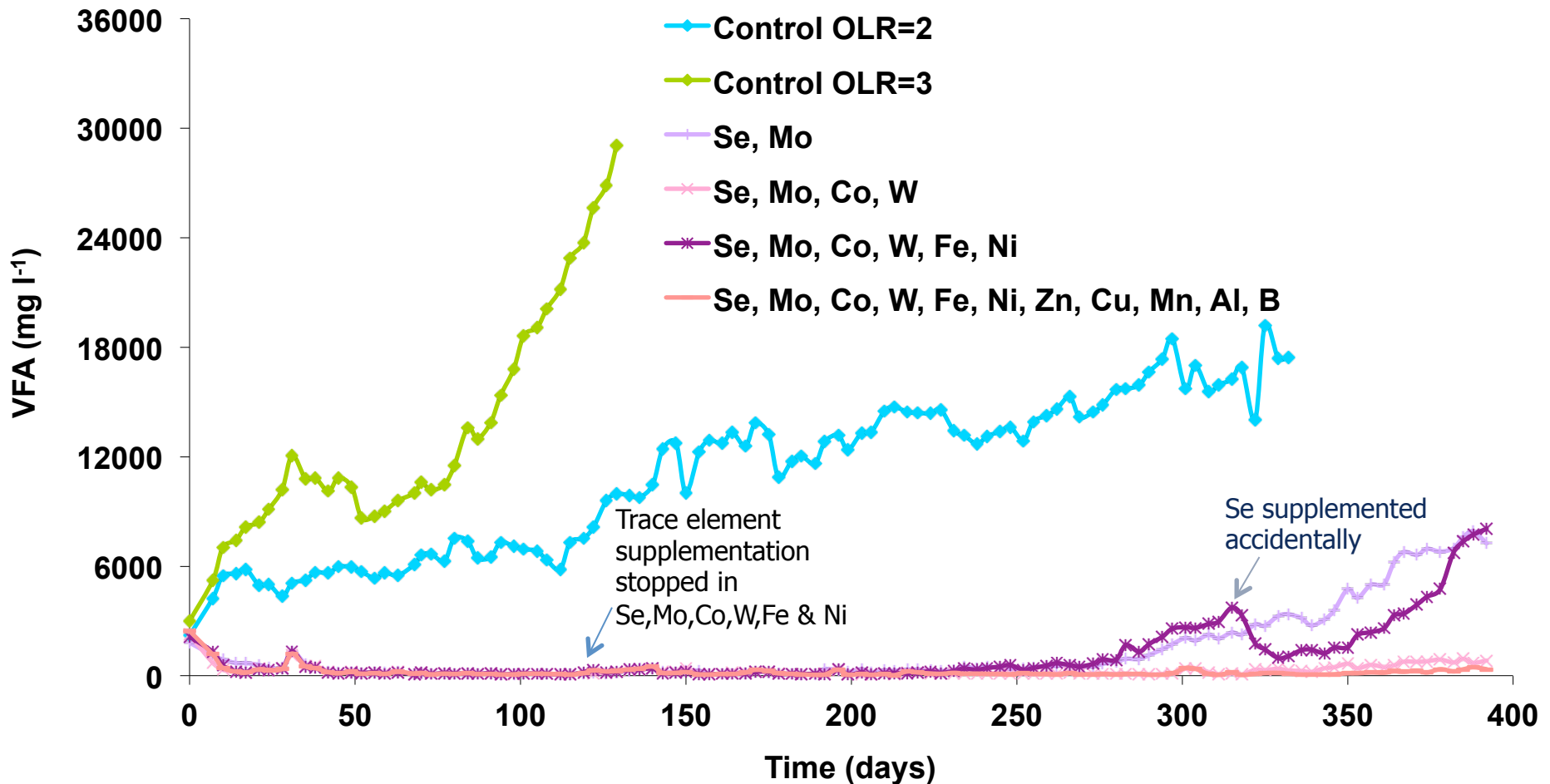



- After addition of micronutrients:
- VFA reduced from >30000 to <1000 mg l^{-1}
- SMP increased from 380 to 420 m^3 $\text{tonne}_{\text{ODM}}^{-1}$.
- OLR increased to 3.2 $\text{kg}_{\text{ODM}} \text{m}^{-3} \text{day}^{-1}$

Metabolic capacity

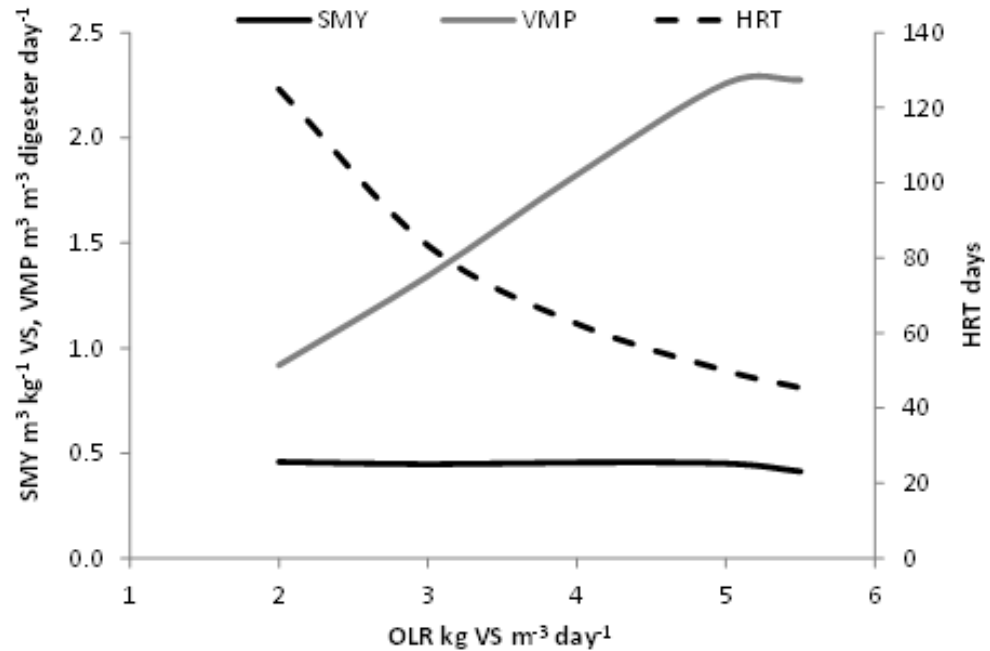
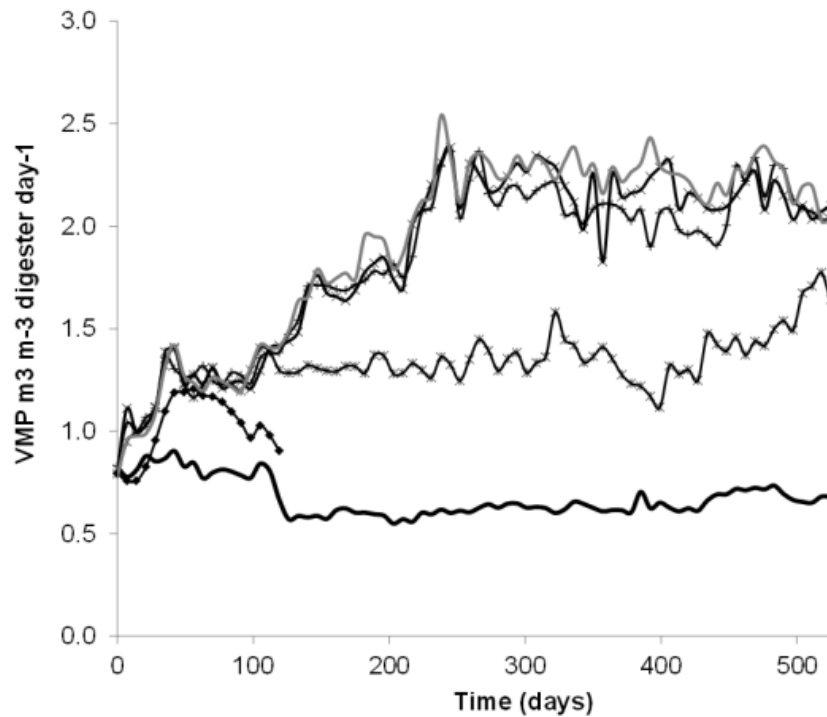

For source segregated domestic food waste

Interactions, inhibitions, and requirement

- We just don't know enough about the anaerobic consortia
 - Sophisticated tools are available

But.....

We need to understand cause and effects and relate these to long-term laboratory and pilot scale trials.

Engineering design

- Data capture and analysis on process energy efficiency
- Rationalisation of process design to meet feedstock characteristics
- Improving mass transfer - mixing
- Hybrid designs for new feedstocks such as algae where solids concentration may be low
- Gas upgrading- reducing energy requirements and slippage
- Solids liquid separation – digestates from many of the new feedstocks (food waste, sugar beet pulp, algae) are difficult to dewater

Process integration

- Already examples of how AD can be coupled to first generation biofuel production
- AD is a natural partner to most biorefinery concepts
- More novel integrations are being proposed e.g. pyrolysis / digestion
- Greater integration into process industries – not just a bolt-on ‘end of pipe’ process

Process modelling

- Develop process models with industry standard software e.g. ASPEN plus
- Adopt tools such as Pinch analysis to maximise energy efficiency in an integrated process
- Enhance and refine whole systems analysis to determine energy ratios for different schemes
- Continue to develop these models to include carbon and nutrient management

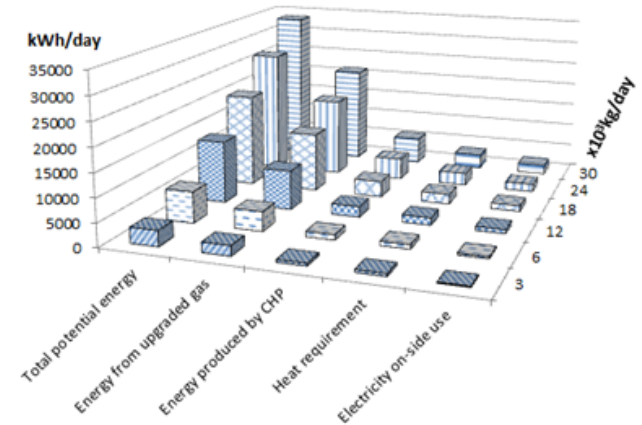
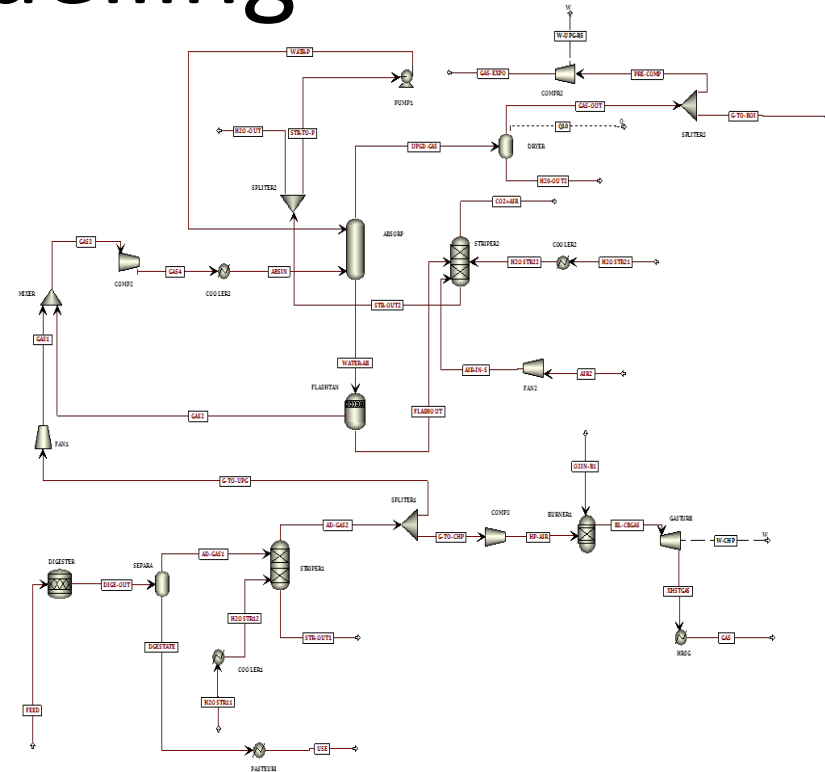

Thanks to:

- IEA Task 37



- Defra



- Wrap



- EU FP7



A tremendous research group at Southampton

and

Thanks to you